

# Flexural properties of sandwich beams consisting of air plasma sprayed alloy 625 and nickel alloy foam

F. Azarmi · T. W. Coyle · J. Mostaghimi

Received: 5 October 2008 / Accepted: 27 February 2009 / Published online: 25 March 2009  
© Springer Science+Business Media, LLC 2009

**Abstract** Sandwich structures are considered as viable engineering constructions due to their unique structural, physical, and mechanical properties. An investigation of the mechanical characteristics of sandwich structures suitable for high temperature application is presented. A process has developed to produce high temperature sandwich structures by depositing alloy 625 skins on Ni alloy foam cores using air plasma spraying (APS). The experimental investigation consisted of fabrication of sandwich structures and testing of mechanical performance of sandwich specimens under flexural loading conditions. The responses of the as-fabricated sandwich structure to heat treatment were investigated. The strength of the sandwich structure was significantly increased after heat treatment. The influence of skin thickness on mechanical behavior of sandwich structures was examined by performing four-point bending test on sandwich samples with skin thicknesses of 0.5 and 0.1 mm. The larger the skin thickness, the higher the strength of the sandwich beams. Comparison between the results of four-point bending tests on sandwich structures with different skin thicknesses will help us to understand the effect of skin thickness on the failure mechanism of sandwich structures.

## Introduction

Sandwich structures represent a special form of laminated structures or composite materials. The basic concept of sandwich structures consists of two thin skins (faces) and a lightweight thicker core. Their structural, physical, and mechanical characteristics can be tailored based on service requirements by selection of different materials and manufacturing processes. This way the properties of each separate component are utilized to the structural advantage of the whole assembly leading to a very high stiffness-to-weight and high bending strength-to-weight ratio [1].

Sandwich structures have lower thermal capacity and thermal conductivity compared to conventionally processed solid materials and exhibit excellent thermal insulation properties which make them attractive for use in industrial and civil applications. Appropriate thermal insulation in buildings becomes more important due to high energy prices, which consequently results increasing heating and cooling costs. Although sandwich structures offer advantages over other types of structures at room temperature, they may be optimized for use at elevated temperatures. The use of sandwich structures continues to increase rapidly for high temperatures applications. Some of the required properties for high temperature applications are low cost, low density, resistance against high temperature, resistance against corrosion, good formability, and ease of production. As one can imagine, it is very hard to find conventionally processed materials which serve all purposes. Sandwich structures which combine the physical and mechanical properties of skin and core components are excellent alternatives. These low-weight structures can be considered good candidates for use in hot sections of heat exchangers and pressure vessels.

---

F. Azarmi (✉)  
Department of Mechanical Engineering and Applied Mechanics,  
North Dakota State University, Fargo, USA  
e-mail: fardad.azarmi@ndsu.edu

T. W. Coyle · J. Mostaghimi  
Center for Advanced Coating Technologies,  
University of Toronto, Toronto, Canada

For sandwich structures designed for high temperature applications it is necessary to use materials which possess good physical and mechanical properties at elevated temperatures. Superalloys can be considered as good candidates for high temperature applications. Nickel-based superalloys offer a combination of microstructural stability, strength, ductility, and toughness at elevated temperatures which normally can not be provided by other metallic compounds [2]. Skin component made from a Ni-based superalloy such as alloy 625 can withstand severe mechanical stresses at elevated temperatures. Metallic foam structures are good candidates for the core due to their outstanding mechanical and physical properties, such as relatively low specific weight, high specific strength, and high stiffness [3–5]. Nickel aluminide intermetallics exhibit acceptable mechanical behavior at room temperature and their mechanical properties improve with increasing temperature. It is expected that the nickel-based alloy foams would exhibit good mechanical properties especially at high temperatures [6]. The sandwich structure consisting of a Ni alloy foam covered by alloy 625 is expected to be a good candidate for high temperature applications.

Numerous techniques have been developed for production of sandwich structures. The most important parameters influencing the fabrication process are: the architecture, core and skin materials, and the quantity to be produced. Among various methods of applying alloy 625 skin on the foam core, thermal spray techniques are the most promising for the rapid deposition of thick sections on the both sides of the foam structure. Thermal spray technique such as air plasma spraying (APS) is suitable methods to apply skin on the surface of complex structures. The fundamental feature of the process is the “heating up” of the powders above their melting point and their acceleration toward a substrate in a hot gas stream. The coating will be formed by the build-up of *splats* resulting from the impact, flattening, and solidification of melted powder particles on the substrate [7–9]. Here, the need for adhesive bonding between core and skin will be eliminated. This type of sandwich structure is easy to fabricate and can be formed into curved shapes due to the flexibility of the coating process and formability of skin and foam components.

Sandwich structures are of most interest for structural applications involving flexural loading, since their structure presents no distinct advantages in specific strength or specific stiffness for in-plane loading conditions. Although not all potential applications of high temperature foam core sandwich structures require exceptional structural performance, the behavior of the structures under flexural loading is often important and provides an indication of the integrity of the sandwich structure. Here, four-point bending tests were performed to measure the effective in-plane elastic modulus (bending modulus) of the

as-fabricated and heat-treated sandwich samples. The results of flexural loading tests were used to qualitatively characterize the mechanical performance of the sandwich structures.

It is commonly believed that the skin layers carry almost all of the bending and in-plane loads and the core acts as a reinforcement constituent which stabilize the facings and defines the flexural stiffness and compressive behavior. Therefore, strengthening of skin may result in increase in stiffness of sandwich structure. It has been shown that heat treatment of a coating structure can enhance cohesion between the individual lamella by diffusion across splat boundaries, and elimination of internal fine porosity [10]. A successful heat treatment operation can also reduce residual stress resulting from the high cooling rate and impact energy of the droplets during the APS process.

A heat treatment schedule was developed and applied to the as-fabricated sandwich structure giving emphasis to improve the mechanical properties of APS deposited alloy 625. This heat treatment process must retain the mechanical properties of Ni alloy foam as well. The effects of heat treatment on the mechanical performance of sandwich beams have also been investigated.

### Bending response of sandwich beams

Some reports suggest that the theories describing the mechanical behavior of traditional composites can be used for sandwich structures, with the addition of special consideration of transverse and torsional shear effects [11]. During operation, sandwich structures under general bending, shear, and in-plane loading display various failure modes. The skin loading can be either compression, tension, or shear. Under uniaxial bending load, while the top skin is in compression the bottom one is in tension. The core is always under shear loads while sometimes compression or tensile loads may be superimposed. The strength of a sandwich structure depends on the material properties of the constituents, geometric dimensions, and type of loading.

A wide range of failure modes including compression and tensile failure of skins, skin/core delamination by interfacial crack propagation, core failure, skin indentation into the core at the loading points (skin failure), and wrinkling of the compressed skin are possible [12]. Figure 1 shows possible failure modes of sandwich structures. Generally, stress analysis is difficult in sandwich constructions because of the complex nonlinear and inelastic behavior of the constituent materials and the problems which arise defining the boundary conditions between shell and core and the complex interactions of failure modes [13].

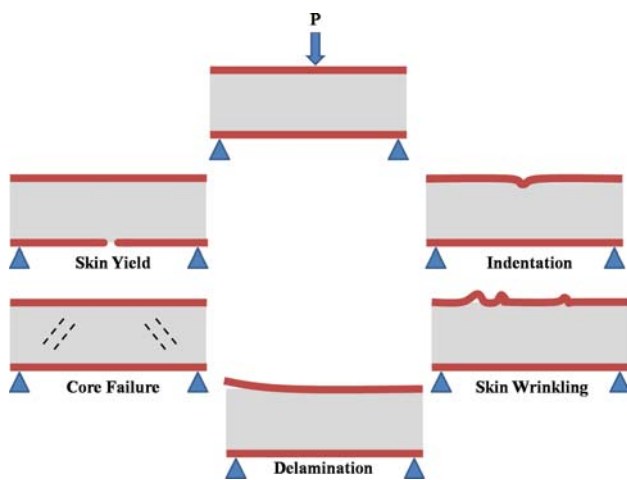

**Fig. 1** Failure modes of sandwich structures under bending load

Skin delamination is the dominant failure mode when the skin-core interfacial strength is insufficient. It is a common problem in hybrid sandwich constructions when the skin and core components are bonded by an adhesive. In this case, failure between the skin material and the core may result in a total loss of structural integrity, leading to complete structural failure of the sandwich beam [14, 15]. So far, a few studies have been performed to identify failure modes in different types of sandwich structures.

Daniel et al. [13] suggested that under bending and shear loads the mechanical behavior of sandwich structures depends on the relative magnitude of the shear components. When the shear component is low (as in the case of long spans), skin wrinkling occurs but the core is still deforming elastically. When the shear component is high (as in the case of short spans), core failure occurs first and then deformation continues by skin wrinkling. McCormack et al. [16] suggested that for sandwich beams with metallic foam cores, skin wrinkling is mostly related to the properties of the core material and stress concentration in the face, not to the debonding of skin/core components.

Typically sandwich structures are subjected to out of plane loadings where the primary loads are applied perpendicular to the panel surface. Thus, they are expected to be strong and stiff in bending. In general, skins are thin and will transmit a significant fraction of the applied load to the core, possibly causing a significant local deformation. A number of recent studies have attempted to determine important aspects of the mechanical behavior of sandwich structures under bending conditions.

The deflection of the sandwich is related to the both flexural and shear deformations. It was previously noted that the core is mostly under shear stress and hence, the approximate expression for the elastic center point deflection ( $\Delta$ ) under load ( $P$ ) is as follows [17]:

$$\Delta = \frac{P(L-S)^2(L+2S)}{48EI_{(eq)}} + \frac{P(L-S)}{4U} \quad (1)$$

where  $U = G(d+c)^2b/4c$  is the shear rigidity and  $G$  is the foam shear modulus.

Consider a sandwich beam subjected to a four-point flexural test where the outer rollers act as supports and the inner ones apply the load as shown in Fig. 3. The skin bending stress ( $\sigma$ ) and the core shear stress ( $\tau$ ) for a sandwich structure subjected to a load  $P$  in four-point bending with an outer span of  $L$  and inner span of  $S = L/2$  are given by Eqs. 4 and 5, respectively [18]:

$$\sigma = \frac{PL}{4t(d+c)b} \quad (2)$$

$$\tau = \frac{P}{(d+c)b} \quad (3)$$

Flexural properties of sandwich constructions, such as the core shear stress, skin bending stress, and flexural rigidity can be obtained from analytical solutions and flexural tests [11, 16, 19–21]. The flexural rigidity of the sandwich beam,  $EI_{(eq)}$ , is calculated as follows:

$$EI_{(eq)} = \frac{E_fbt(d^*)^2}{2} + \frac{E_fbt^3}{6} + \frac{E_cbc^3}{12} \quad (4)$$

Equation 4 was derived according to the *Parallel axis theorem*, where  $E_f$  and  $E_c$  are the elastic moduli of the skin and core materials, respectively,  $d$  is the sandwich thickness,  $c$  is the core thickness,  $t$  is the skin thickness, and  $b$  is the sandwich width,  $d^*$  is the distance between the center lines of the upper and lower skins as shown in Fig. 2.

## Experimental procedure

In this section, the materials used to fabricate skin and core sections of sandwich beams are introduced. The details of APS technique for fabrication of sandwich samples is explained followed by experimental procedure of four-point bending test.

### Materials

#### *Nickel alloy foam (core material)*

Due to availability, nickel foam aluminized with about 10 wt% aluminum fabricated by Fibernide Ltd, Brampton, Canada<sup>1</sup> was used as core component in the sandwich structure. The strut thickness of the as-received nickel alloy foams ranged from 0.3 to 0.8 mm and the strut length ranged from 0.3 to 3 mm with an average pore size of

<sup>1</sup> <http://www.fibernide.com>.

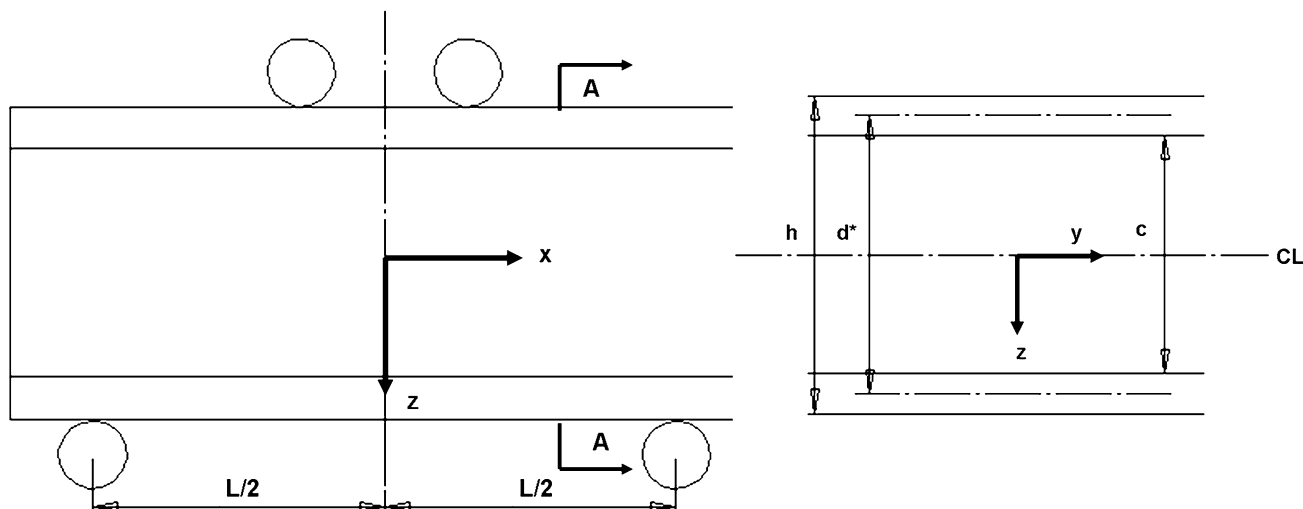

**Fig. 2** Schematic of the sandwich structure. A cross-section through A–A is shown on the right

2.5 ± 1.5 mm. The available samples were 178 × 101 × 9 mm<sup>3</sup>. All the as-received foams were filled with graphite to fill the void spaces between the struts. This graphite was removed from the foam after spraying process by low temperature oxidation in air followed by mechanical agitation. The chemical composition of Ni alloy foam from Inductively Coupled Plasma Atomic Emission Spectroscopy (ICP-AES) is given in Table 1.

*Alloy 625 powder (skin material)*

Commercially available spheroidal, gas atomized powders of composition similar to Inconel 625, Metco AMDRY 625 used for the experiments. The nominal composition for this powder is 21.5 wt% Cr, 8.5 wt% Mo, 3 wt% Nb, 3 wt% Fe, 0.5 wt% Co, remainder Ni. The nominal particle size is in the range of –90 to +45 μm for AMDRY 625.

*Fabrication of sandwich structure*

*Preparation of substrate*

A simple grit-blasting operation was performed on each side of nickel foam prior to the coating process. This process will remove an appropriate amount of graphite from the both sides of the foam (surfaces) and inserts the skin deeper into the foam surface. Grit-blasting operation

will also increase the adhesion between coatings and foam struts by roughening the strut surface.

*Spraying process*

The nickel foam substrates were placed inside a window in the sample holder fixed on a table facing the spraying gun during the deposition. Alloy 625 powder (AMDRY 625) was air plasma sprayed using a Praxair (formerly Miller Thermal) SG-100 torch (Praxair Surface Technologies, Indianapolis, IN, USA) mounted on a computer controlled robotic arm at atmospheric pressure. The robot was programmed to scan across and down the substrate for a given number of cycles. A 60C powder feed unit (Sulzer Metco, Switzerland) was used with the plasma spray system.

The optimized process parameters determined in the previous study were used for deposition of alloy 625 coatings on the foam structure as shown in Table 2 [22]. The alloy 625 skin can then be deposited on to the surfaces using the optimized process parameters. Two different types of sandwich structures with skin thicknesses of 0.1 mm and 0.5 mm were fabricated by deposition of 100 and 500 μm of alloy 625 coating on each side of nickel foams.

*Heat treatment procedure*

Although the main reason for the heat treatment is to improve mechanical properties of the as-sprayed coating,

**Table 1** Chemical composition of Ni alloy foam using (ICP-AES)

Element:	Composition						Total
	Ni	Al	Fe	Co	Mn	Si	
Wt% or PPM conc.	90.0%	9.27%	340.59 PPM	573.53 PPM	5.0 PPM	500 PPM	100%

**Table 2** Air plasma spraying parameters used in this study [22]

Parameter	Powder size ( $\mu\text{m}$ )	Spray distance (mm)	Feed rate (g/min)	Current (A)	Power (kW)	Ar gas flow slm
Value	78	50	28	630	25	55

extra care must be taken to avoid damaging the foam structure. Various temperatures recommended for solution annealing of conventionally processed alloy 625 were used for heat treatment of sandwich samples. Sandwich structure specimens were heat treated at 1100 °C for 5 h under low pressure ( $\sim 10^{-2}$  to  $2 \times 10^{-2}$  Torr) using a high-temperature vacuum furnace (R. D. WEBB Co, USA). The heat treatment cycles are presented in Fig. 3.

Porosity, cracks, and weak bonding between splats contribute to displacements under applied stress, resulting in a lower apparent elastic modulus. Previous study showed that the effective heat treatment can improve tensile properties of as-sprayed alloy 625 [23]. Heat treatment of a coating may enhance cohesion between the individual lamella through diffusion bonding across the splat boundaries and elimination of fine porosity. A successful heat treatment operation can also reduce residual stresses due to the high cooling rate and impact energy of the droplets during the process. The results indicated a significant improvement in the mechanical properties of the as-sprayed coatings due to the post deposition heat treatment.

SEM images of coating cross-sections are shown in Fig. 4 for as-sprayed and heat-treated samples. The rounded shapes of unmelted or partially melted particles are visible in these images. Areas of three discernable levels of contrast, black, gray, and white, are seen. The black regions are identified as pores. The majority of the pores are rounded in shape, but some of them can also be identified along the interface of the splats. The amount of gray region is lower in the heat-treated samples.

**Fig. 3** Heat treatment cycles for the as-fabricated sandwich samples based on conventional heat treatment schedules for alloy 625

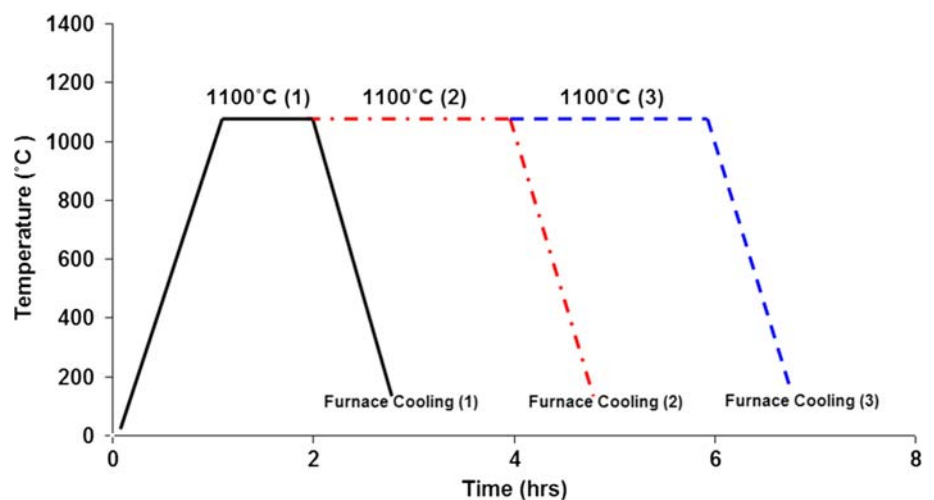

#### Four-point bending test

The test specimens were mounted in a four-point bending test fixture which was designed and built based on ASTM C 393-00 and ISO 14704 specifications [18–20, 24]. The test set-up was assembled on the frame of a tensile test machine (model 1331, Instron, MA, USA). The test fixture consists of a fixed base plate, a pair of holders for the lower loading rollers, an upper loading block to maintain the alignment of the upper rollers, two pair of loading rollers, and an extensometer to measure the vertical displacement at the center of the test sample. An Instron 8800—compatible desktop computer collected the raw data using a DAX data acquisition program. The lengths of the inner and outer spans of the fixture were 20 and 40 mm. Figure 5 shows a schematic of the test set-up.

Test specimens were cut from degreased sandwich panels with skin thicknesses of 0.5 and 0.1 mm. The specimen dimensions were 70 mm L  $\times$  20 mm W. The samples were aligned in the fixture by two guide pins. Once the sample was mounted and centered in the fixture, the upper block and rollers were centered over the sample using a guide block. The load was applied on a spherically tipped pin with a crosshead displacement rate of 0.01 mm s<sup>-1</sup>.

#### Results and discussion

The results of four-point bending tests performed on the as-fabricated and heat-treated sandwich samples with skin thicknesses of 0.5 and 0.1 mm are presented. Comparison



**Fig. 4** SEM image of cross-section of alloy 625 coating illustrating three discernable levels of contrast, **a** as-sprayed, **b** heat-treated sample

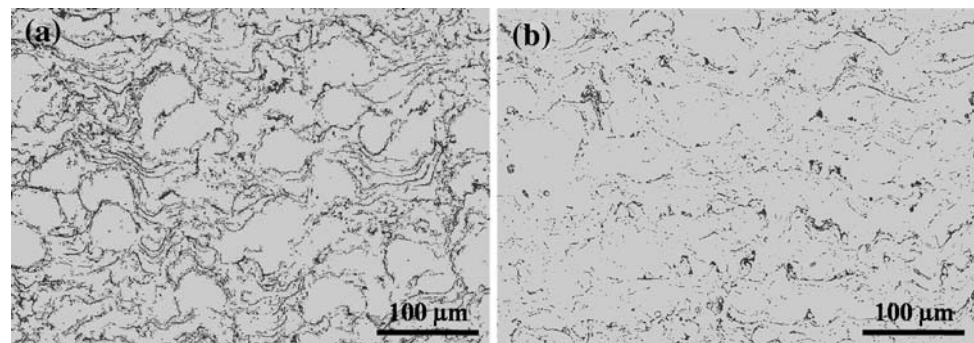

**Fig. 5** Four-point bending test set-up

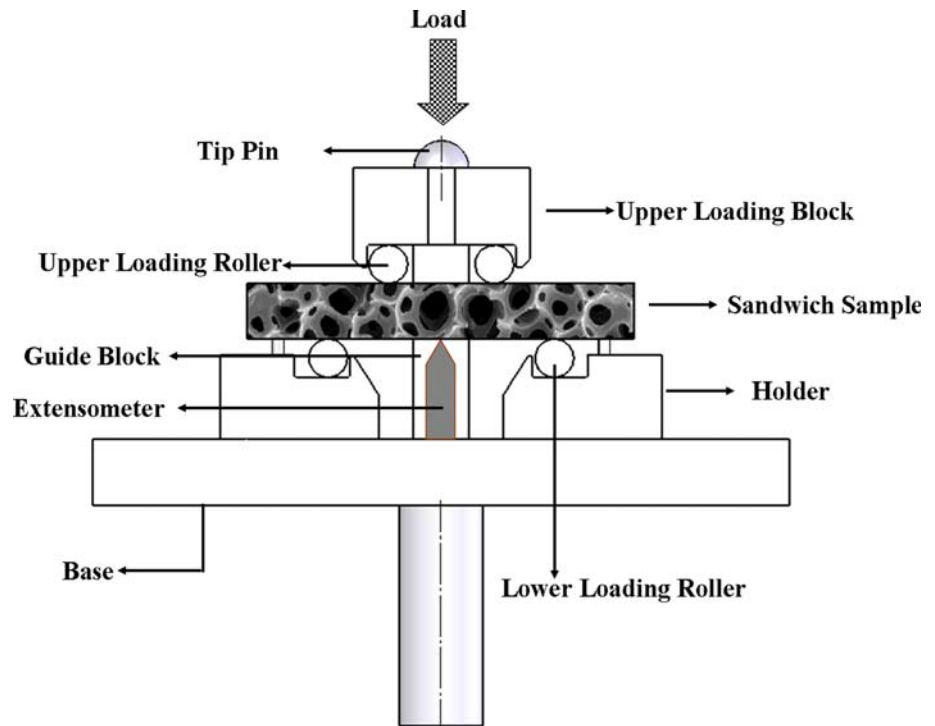

between the results of four-point bending tests on sandwich beams with different skin thicknesses will help us to understand the effect of skin thickness on the failure mechanism of sandwich structures. These results also show the effect of post fabrication heat treatment on the mechanical performance of the sandwich structures.

The flexural rigidity,  $EI_{(eq)}$ , for a sandwich structure can be determined from the curve of load versus center point deflection in the elastic region using Eq. 4. The center point deflection is  $\Delta = (Y_L + Y_R)$  where  $Y_L$ , the load point displacement, is approximately equal to the crosshead displacement (Fig. 6).  $Y_R$  is the distance between deflected center point and crosshead position. The center point deflection was measured directly on the beam using an extensometer. Load versus center point deflection curves obtained from four-point bending tests on the as-fabricated and heat-treated samples with a skin thickness of 0.5 mm are shown in Fig. 7.

Figure 7 compares load versus center point displacement curves for the as-fabricated and heat-treated sandwich samples (5 h) with skin thickness of 0.5 and 0.1 mm. The graphs show that the strength and the deflection at failure of the sandwich structures with the thick skin are greater than those with the thinner skin, for both the as-fabricated and heat-treated samples.

It is clear from the load versus center point displacement curves shown in Fig. 7 that the post fabrication heat treatments have improved the mechanical performance of the as-fabricated sandwich structure regardless of their skin thicknesses. The flexural rigidity was significantly increased after the 5-h heat treatment.

All the curves obtained for sandwich structures with 0.5 mm skin thickness shown in Fig. 7 are typical of curves obtained when failure occurs by indentation (skin failure). The curves exhibit three different stages. The load–displacement curve is initially linear in the elastic region.

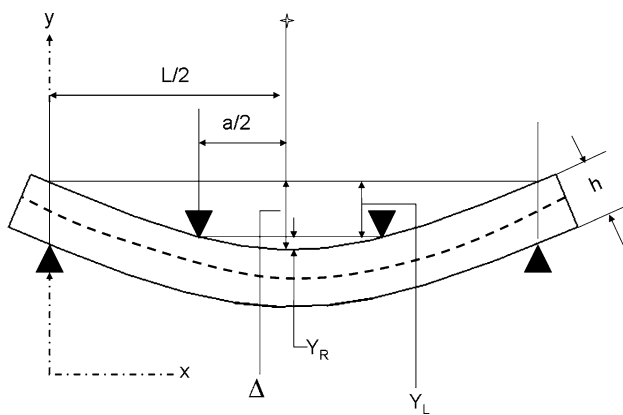

**Fig. 6** Schematic diagram of the bended bar during four-point bending test

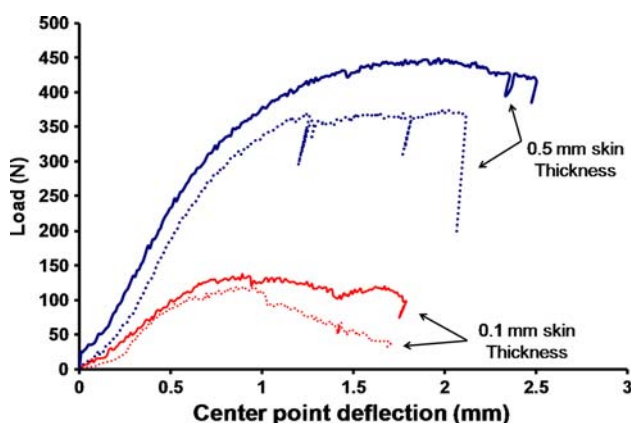
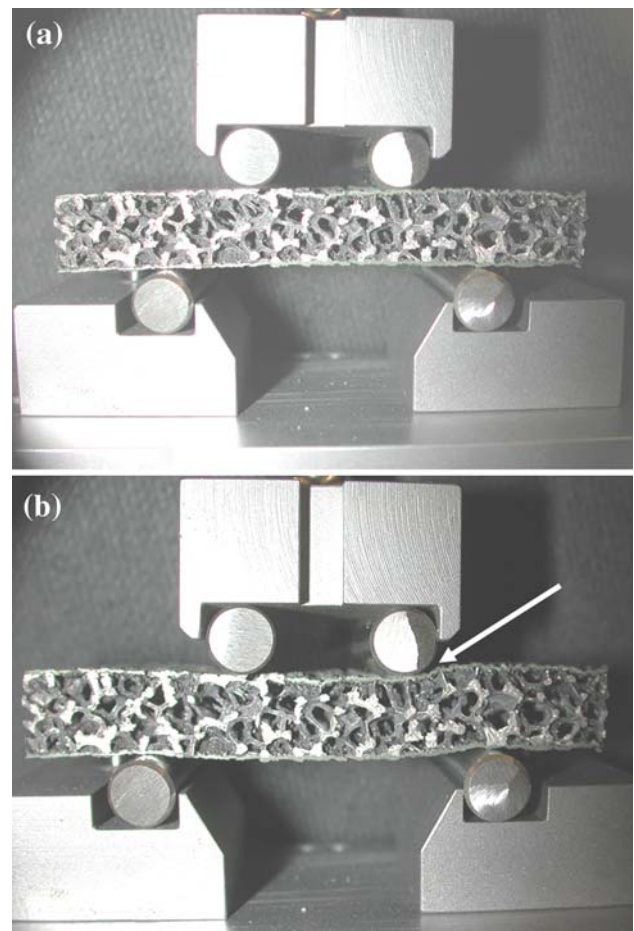

**Fig. 7** Comparison of the load versus center point displacement curves obtained from four-point bending tests on sandwich samples with skin thicknesses of 0.1 and 0.5 mm (Solid lines show heat-treated samples for 5 h and dotted lines show as-fabricated samples)

Beyond the linear regime, the stress increases non-linearly, due to plastic indentation of the skin. The rapid decrease in the load occurs when a crack develops in the skin, leading to failure of the sample. The average collapse load obtained from the six as-fabricated and heat-treated samples with skin thickness of 0.5 mm were  $368 \pm 50$  and  $420 \pm 45$ , respectively.

Figure 8 shows a sandwich structure heat treated for 5 h with a skin thickness of 0.5 mm before, and after four-point bend testing. Failure by skin indentation can be clearly seen in the region indicated by the arrow in Fig. 8b.

The load versus center point displacement curves for sandwich samples with skin thickness of 0.1 mm in Fig. 7 are typical of curves for core yielding failure, suggesting that the dominant failure mode for these sandwich structures is core yielding. In this case the skin is not stiff enough to carry the load and failure of the structure depends on the foam strength. The load–displacement graph is linear in the beginning of the test. If the load



**Fig. 8** A four-point bending test sandwich sample with skin thickness of 0.5 mm **a** before, and **b** after test

passes the elastic limit of the foam, the load increases non-linearly due to the plastic deformation and/or localized fracture of struts in the foam core. The average collapse load obtained from the five as-fabricated and heat-treated samples with skin thickness of 0.1 mm were  $41 \pm 5$  and  $98 \pm 14$ , respectively. Figure 9 shows a sandwich structure heat treated for 5 h with a skin thickness of 0.1 mm after four-point bending test. At failure, cracks extend through the thickness of the foam as shown by the arrows in Fig. 9. These results are in agreement with observations reported for dependence of the failure mechanism on the core and skin thickness in sandwich beams with metallic cores [19]. Unsymmetrical deformation is due to inhomogeneity in pore distribution among the foam structure as core component is the major load carrier in these beams. The regions with lower density (more porosity and less strut thicknesses) will deform more under similar loading condition.

Table 3 compares the experimentally determined  $EI_{(eq)}$  for the as-fabricated and heat-treated sandwich samples. As in the previous tests, the center point deflection was

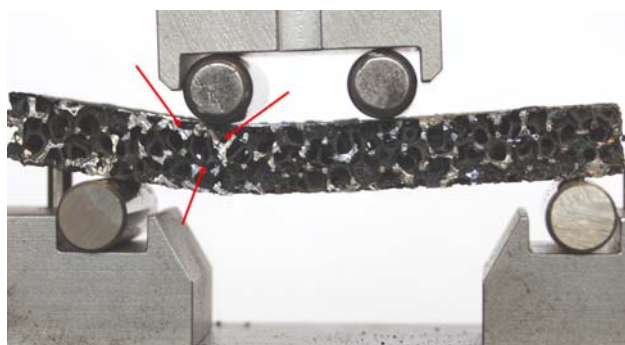

**Fig. 9** An image of deflected beam with skin thickness of 0.1 mm at the end of loading, where the structure failed by core yielding

**Table 3** Comparison of the experimentally determined  $EI_{(eq)}$  for the as-fabricated and heat-treated sandwich samples

	As-fabricated		Heat treated (5 h)	
	Skin thickness (mm)		Skin thickness (mm)	
	0.1**	0.5*	0.1**	0.5*
$EI_{(eq)}$ (Nm <sup>2</sup> )	1.20 ± 0.10	4.50 ± 0.50	2.60 ± 0.30	5.60 ± 0.50

\* Average of 6 measurements ± 1 standard deviation

\*\* Average of 5 measurements ± 1 standard deviation

recorded directly from the extensometer located at the center of the sandwich sample. These results indicated that larger the skin thickness, larger the flexural rigidity of the sandwich samples. The flexural rigidity of the as-fabricated samples, regardless of the skin thickness, was significantly increased after heat treatment for 5 h. It is due to the improvement of the mechanical properties of alloy 625 coatings significantly with application of heat treatment.

**Conclusions**

Sandwich structures were developed for high temperature applications comprising APS deposited alloy 625 skins and nickel alloy foam core. This study reports the results of an investigation on the mechanical performance of high temperature sandwich structures under four-point bending load condition. This study also monitors damage development in the sandwich structures via changes in load versus center point deflection graph obtained from four-point bend testing. It is followed by direct observation of tested sandwich samples at failure to monitor crack propagation due to flexural loading.

The flexural rigidity and strength of the sandwich structure depends on the skin thickness. Increasing the skin thickness increased the flexural rigidity. The flexural rigidity and strength of the sandwich structure is significantly

increased after heat treatment for 5 h at 1100 °C for both skin thicknesses. The dominant failure mode observed for all the sandwich samples with skin thickness of 0.5 mm was skin indentation. The dominant failure mode for sandwich structures with skin thickness of 0.1 mm was core yielding.

**References**

- Vinson JR (1999) The behavior of sandwich structures of isotropic and composite materials. Technomic Publishing Company, Lancaster
- Wahl MJ (1979) Handbook of superalloys. International Alloy Compositions and Designations Series, Battelle Press, Columbus
- Swellam M, Yi S, Fouad Ahmad M, Huber LM (1997) J Appl Polym Sci 63:383
- Banhart J (2001) Prog Mater Sci 46:559
- Evans AG, Hutchinson JW, Fleck NA, Ashby MF, Wadley HNG (2001) Prog Mater Sci 46:309
- Singleton MF, Murray JL, Nash P (1991) Phase diagrams of binary nickel alloys. ASM International, Materials Park, OH
- Azarmi F (2005) Adv Mater Processes 163(8):37
- Heimann RB (1996) Plasma spray coating—principles and application. VCH Publishing, New York
- Fauchais P (2004) J Phys D Appl Phys 37:086
- Salimi Jazi HR, Coyle TW, Mostaghimi J (2007) Metall Mater Trans A 38:476
- Caprino G, Teti R (1989) Sandwich structures: handbook. II Prato, Padua
- Ashby MF (2005) Materials selection in mechanical design, 3rd edn. Butterworth-Heinemann, Oxford
- Daniel IM, Gdoutos EE, Abot JL, An-Wang K (2003) J Thermoplast Compos Mater 16(4):345
- Cantwell WJ, Davies P (1996) Appl Compos Mater 3:407
- Cantwell WJ, Scudamore R, Ratcliff J, Davies P (1999) Compos Sci Technol 59:2079
- McCormack TM, Miller R, Kesler O, Gibson LJ (2001) Int J Solids Struct 38:4901
- Thomsen OT, Bozhevolnaya E, Lyckegaard A (2005) In: Advancing with sandwich structures and materials. Proceedings of the 7th International Conference on Sandwich Structures, Aalborg University, Aalborg, Denmark, p 29
- ASTM International (2000) Standard test method for flexural properties of sandwich constructions. Designation: C 393-00, Annual Book of ASTM Standards, v 03.01
- Belingardi G, Cavatorta MP, Duella R (2003) Compos Struct 61:13
- Mohan K, Hon YT, Idapalapati S, Seow HP (2005) Mater Sci Eng A 409:292
- Allen H (1969) Analysis and design of structural sandwich panels. Oxford Pergamon Press, New York
- Azarmi F, Coyle TW, Mostaghimi J (2008) J Therm Spray Technol 17(1):144
- Azarmi F, Coyle TW, Mostaghimi J (2009) Surf Coat Technol 203:1045
- Draft International Standard ISO/DIS 14704 (2007) Fine ceramics (advanced ceramics, advanced technical ceramics)—test method for flexural strength of monolithic ceramics at room temperature. International Organization for Standardization